

NOTES

1. WHEN THIS DRAWING IS USED AS AN ORDER SUBMITTAL, IT MUST BE SIGNED, AND AN ORDER SUBMITTAL FORM MUST BE INCLUDED.
2. 1 YEAR WARRANTY COVERAGE - SEE DECONTAMINATION HOLDING TANK LIMITED WARRANTY FOR DETAILS
3. OPTIONAL ACCESSORIES ARE ALSO AVAILABLE.

DESIGN PARAMETERS

1. VINYL ESTER RESIN ON TANK INTERIOR.
2. TANK SIZE: 4' DIA DOUBLE-WALL, 49" O.D. (DRY MONITOR)
3. NOMINAL TANK CAPACITY: 1,500 GALLONS.
4. NOMINAL TANK WEIGHT: 2,100 LBS.

APPROVAL

THE UNDERSIGNED ACKNOWLEDGES AND AGREES TO THE USE AND DESIGN PARAMETERS AS DETAILED ON THIS DRAWING AND IN THE ACCOMPANYING ORDER SUBMITTAL FORM AND HEREBY APPROVES FABRICATION.

SIGNATURE _____

PRINTED NAME _____ DATE _____

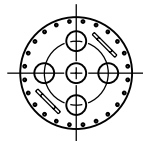

MANWAY COVER CONFIGURATION

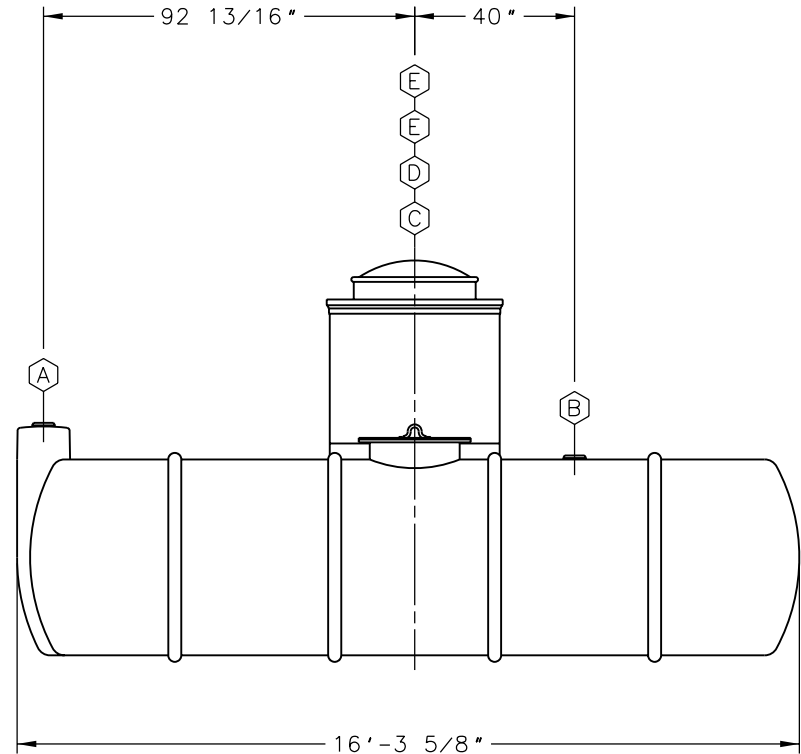

ITEM	QTY	DESCRIPTION
(A)	1	4*NPT MONITOR FITTING
(B)	1	4*NPT SERVICE FITTING
(C)	1	22*DIA MANWAY WITH 5-4*NPT FITTINGS IN COVER
(D)	1	42*DIA SW CONTAINMENT COLLAR & 36*HIGH SW SUMP WITH 30*DIA LEVER LOCK WATERTIGHT TOP
(E)	2	LIFTING LUG (1 EXTRA) (MOUNTED ON MANWAY COVER)

ZCL® | XERXES®

TITLE
**MODEL DC-4-1500
 DECONTAMINATION TANK**

DATE 1-17 DR. NO. S11-972.00

INDUSTRY TYPE: M210 PLUMBING ENGINEERED SOLUTIONS